



Seated Tricep Extension ASSEMBLY INSTRUCTIONS



Please take the time to carefully read the instruction manual before starting the process of assembling your machine. If you have any inquiries or complications, please call us at 662-GYM-BROS, or email us at info@gymbrofitness.com.

Ensure to tighten all nuts and bolts, lubricate any sliding parts, bearings, and moving mechanisms. We also suggest applying Loctite or any kind of thread locking adhesive to anything that does not thread into a Teflon nut. It is also important to ensure that every movement arm is properly aligned prior to frequent use, and that the machine that you are assembling is fully functional.

Tools Required for Installation:
Rubber Mallet
Level
Ratchet and Socket Set
Snap Ring Pliers
Adjustable Wrench
2 People Required

PARTS/HARDWARE LIST

Part Number	Part Description	Quantity
1	Support	1
2	Support	1
3	Cross Assembly	1
4	Upper Cross Assembly	1
5	Arm Pad Frame	1
6	Pivotal Pad Mount	1
7	Arm Support	1
8	Swing Arm Tube	1
9	Connecting Plate	1
10	Seat Support 95	1
11	Plastic Panel 2	4
12	Shaft	2
13	Hexagon Nuts Grade M16	5
14	Hexagon Socket Countersunk Head Screws M8x70	2
15	Plain Washers - Product Grade 12	27
16	Hexagon Head Bolts - Product Grade M8x70	2
17	Plastic Washer - 40x10.5x2	4
18	Hexagon Socket Button Head Screws M10x25	4

PARTS/HARDWARE LIST Continued

Part Number	Part Description	Quantity
19	50 100 End Cap	16
20	Arm Pad Assembly	1
21	Arm Pad Assembly	2
22	Back Pad Assembly	1
23	Seat Pad Assembly	1
24	Bearing L205	4
25	Weight Stack Bumper	2
26	Hexagon Socket Head Cap Screws M10x45	4
27	Weight Holder 80	1
28	Hexagon Head Bolts - Product Grade M12x70	20
29	Rubber Grip 300	2
30	Hex Head Bolts -Full Thread Grade M12x25	4

Assembly

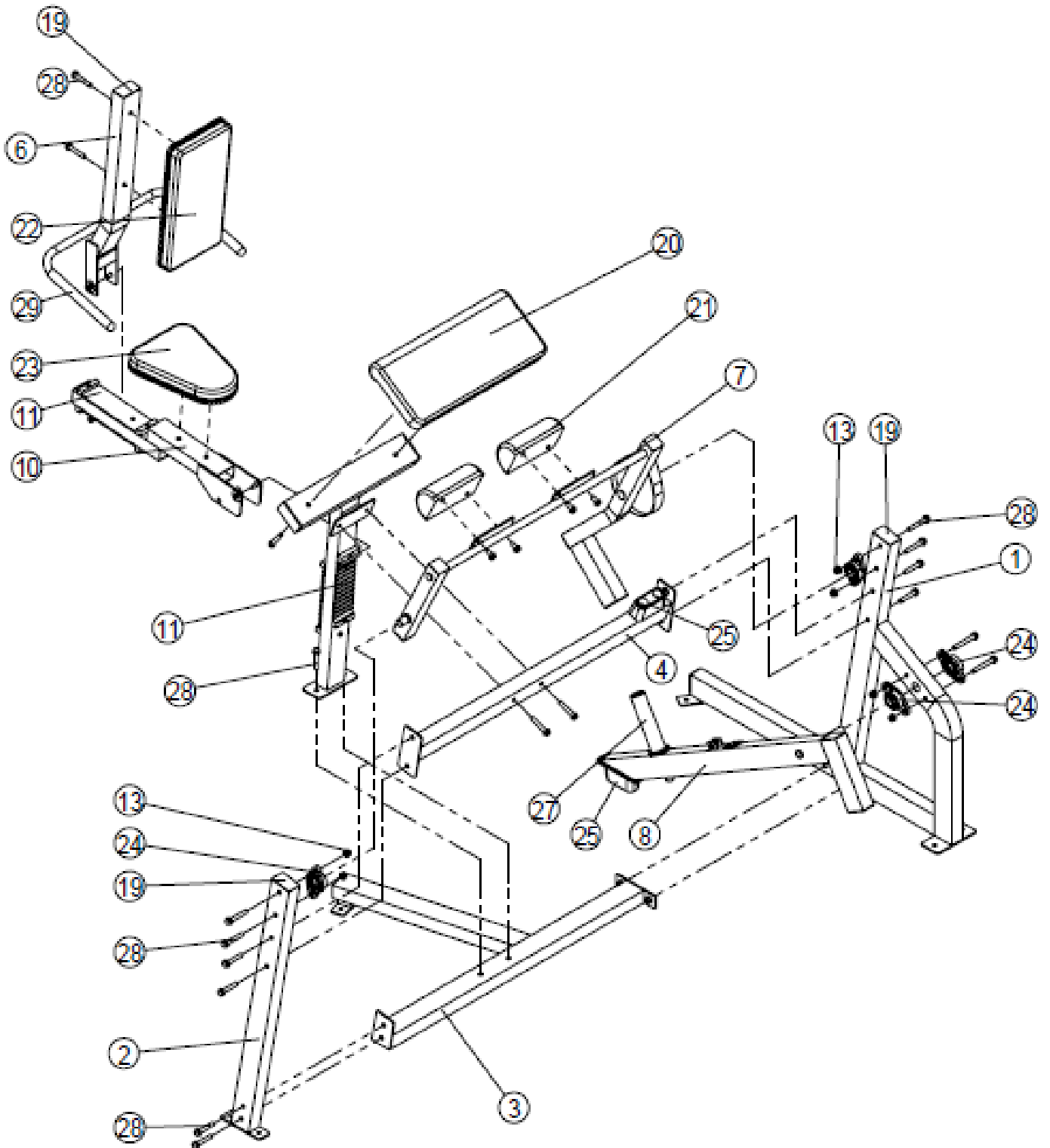

Final Product

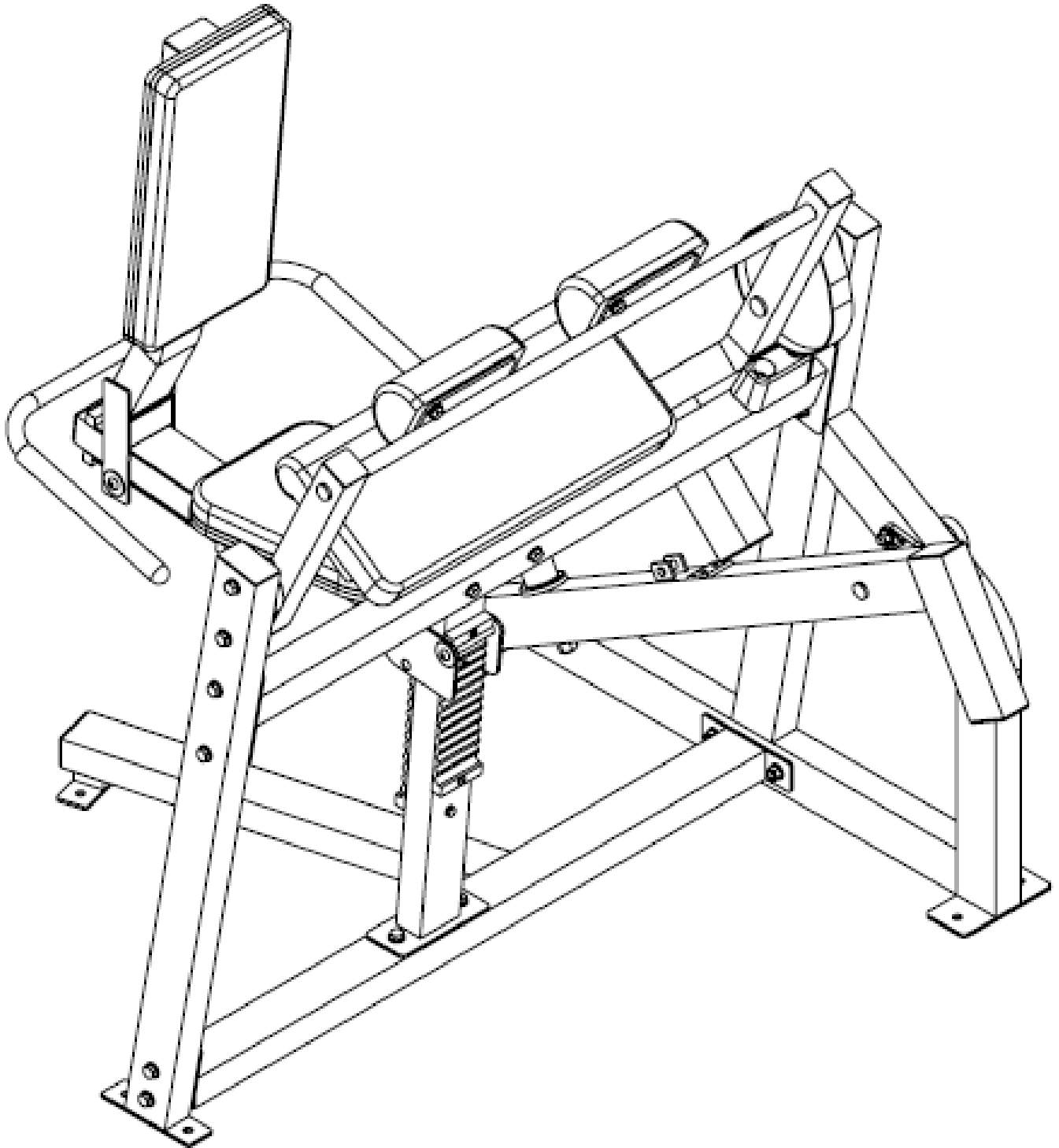

Have a question about assembly?



Please contact a Gym Bro Fitness Team Member!

Hours of Operation:

Monday-Friday 9:00am - 5:00pm (PST)

Saturday 9:00am - 3:00pm (PST)

Sunday CLOSED

Phone: (662)GYM-BROS

Email: info@gymbrofitness.com

Visit Our Website: www.gymbrofitness.com