



# Shoulder Press Plate Loaded ASSEMBLY INSTRUCTIONS



**Please take the time to carefully read the instruction manual before starting the process of assembling your machine. If you have any inquiries or complications, please call us at 662-GYM-BROS, or email us at [info@gymbrofitness.com](mailto:info@gymbrofitness.com).**

**Ensure to tighten all nuts and bolts, lubricate any sliding parts, bearings, and moving mechanisms. We also suggest applying Loctite or any kind of thread locking adhesive to anything that does not thread into a Teflon nut. It is also important to ensure that every movement arm is properly aligned prior to frequent use, and that the machine that you are assembling is fully functional.**

<b>Tools Required for Installation:</b>
Rubber Mallet
Level
Ratchet and Socket Set
Snap Ring Pliers
Adjustable Wrench
2 People Required

## PARTS/HARDWARE LIST

<b>Part Number</b>	<b>Part Description</b>	<b>Quantity</b>
A1	Main Frame	1
A2	Connection Frame (1)	1
A3	Connection Frame (2)	1
A4	Side Frame	1 pair
A5	Arm Support Frame	1
A6	Arm	1 pair
A7	Cushion Frame	1
1	Footpads	5
2	Hexagon Socket Flat Head Screws M12x70	14
3	Flat Pad (1)	14
4	Flat Pad (2)	20
5	Self Locking Nut M12	14
6	Hexagon Socket Head Screws M12x30	4
7	Square End Cap	4
8	Sleeve Pad	4
9	Sleeve End Cap	4
10	Sleeve Tube	4
11	Sleeve End Cap	6
12	Hexagon Socket Head Screws M10x15	10
13	Deep Groove Ball Bearings	4

## PARTS/HARDWARE LIST Continued

<b>Part Number</b>	<b>Part Description</b>	<b>Quantity</b>
14	Handle End Cap	2
15	Handle Cover	2
16	Handle Limit Ring	2
17	Flat Pad	4
18	Arm Axis	2
19	Hexagon Socket Head Screws M10x35	4
20	Dampening Piece	2
21	Hexagon Socket Head Screws M12x20	2
22	Sleeve End Cap	2
23	Sleeve Rod	2
24	Sleeve Tube	2
25	Back Pad	1
26	Hexagon Socket Head Screws M8x30	8
27	Flat Pad	8
28	Cushion Pin	1
29	Middle Pass Cover	1
30	Cushion Group	1

# Frame Assembly

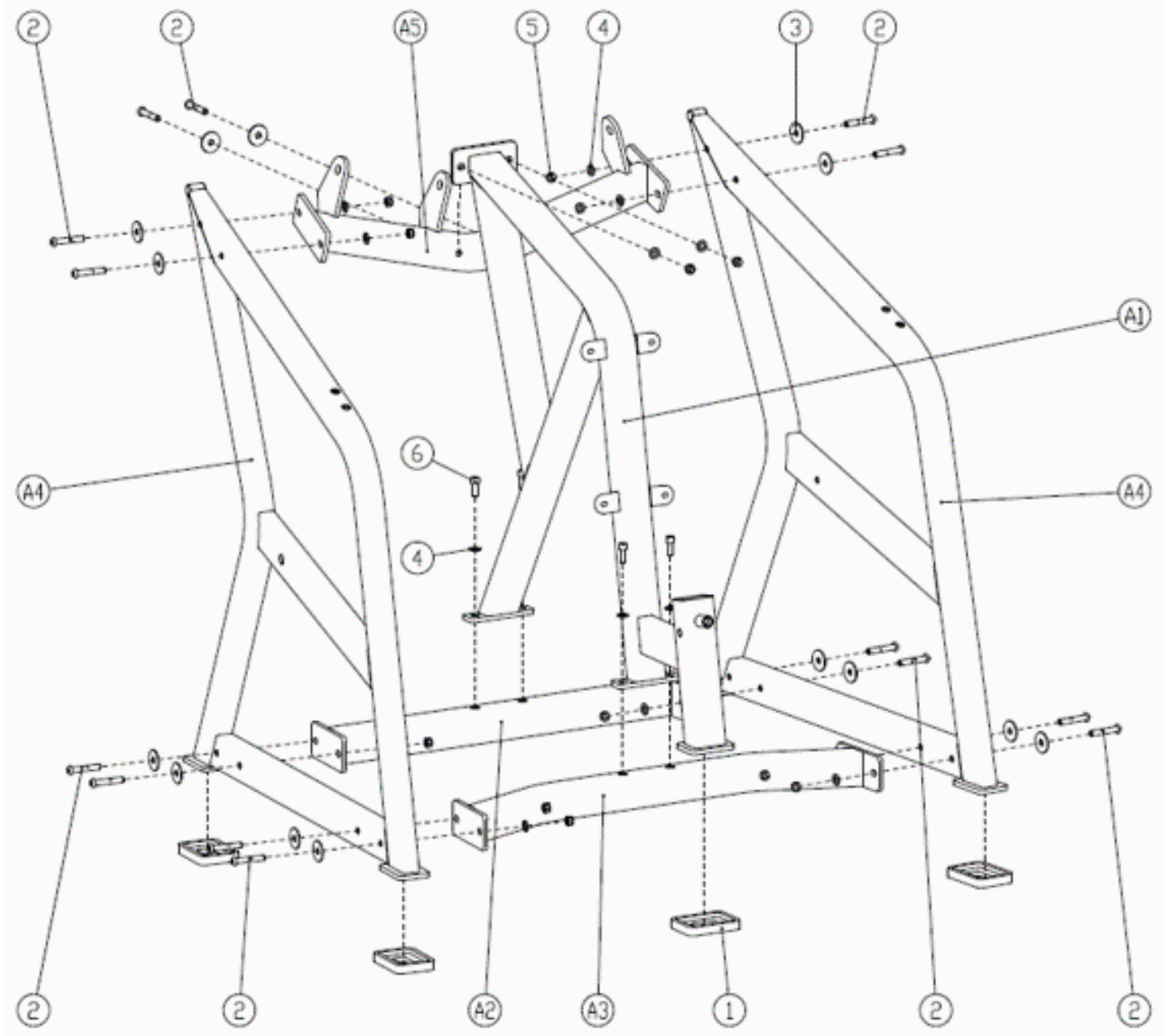

# Force Arm Assembly

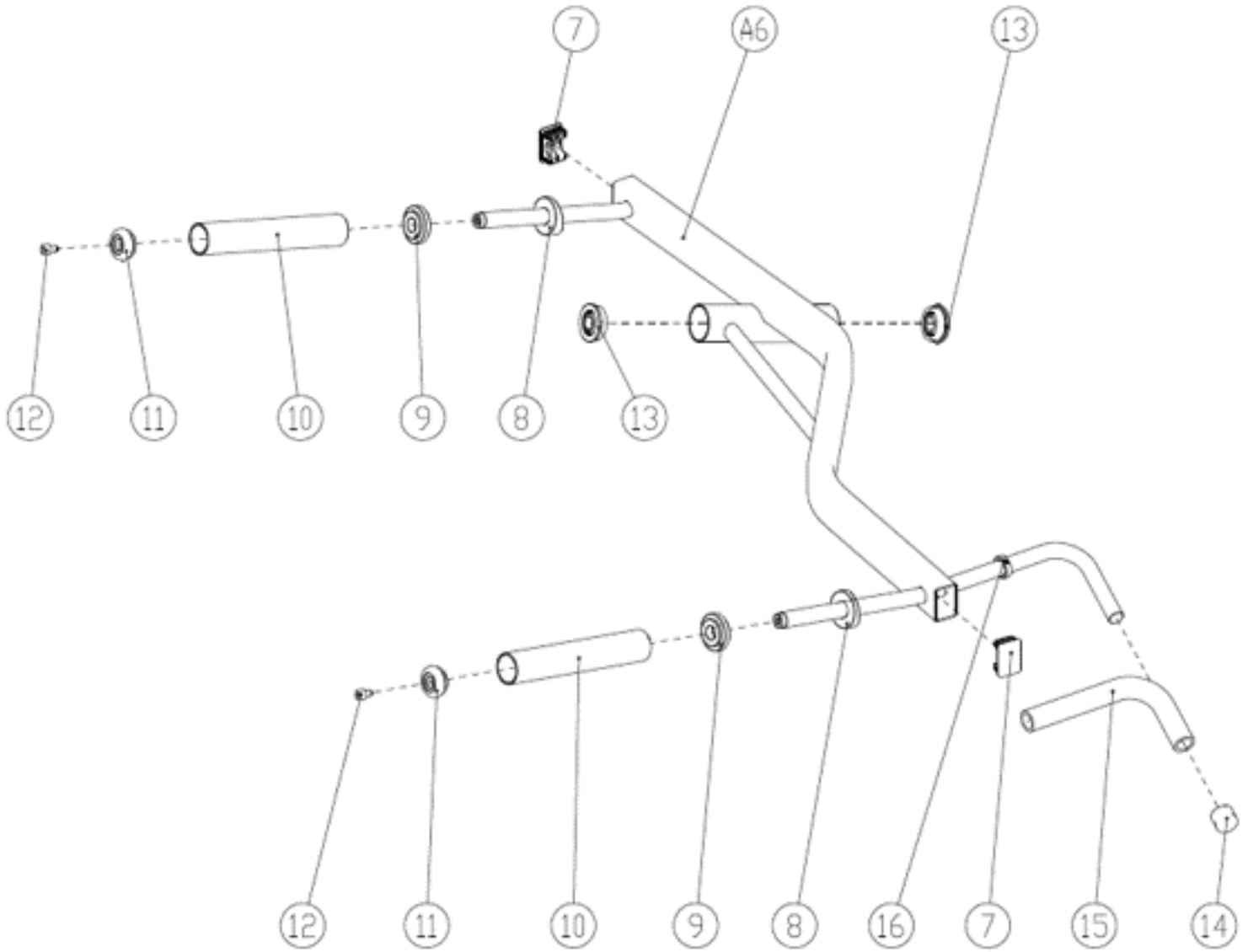

# Force Arm Installation

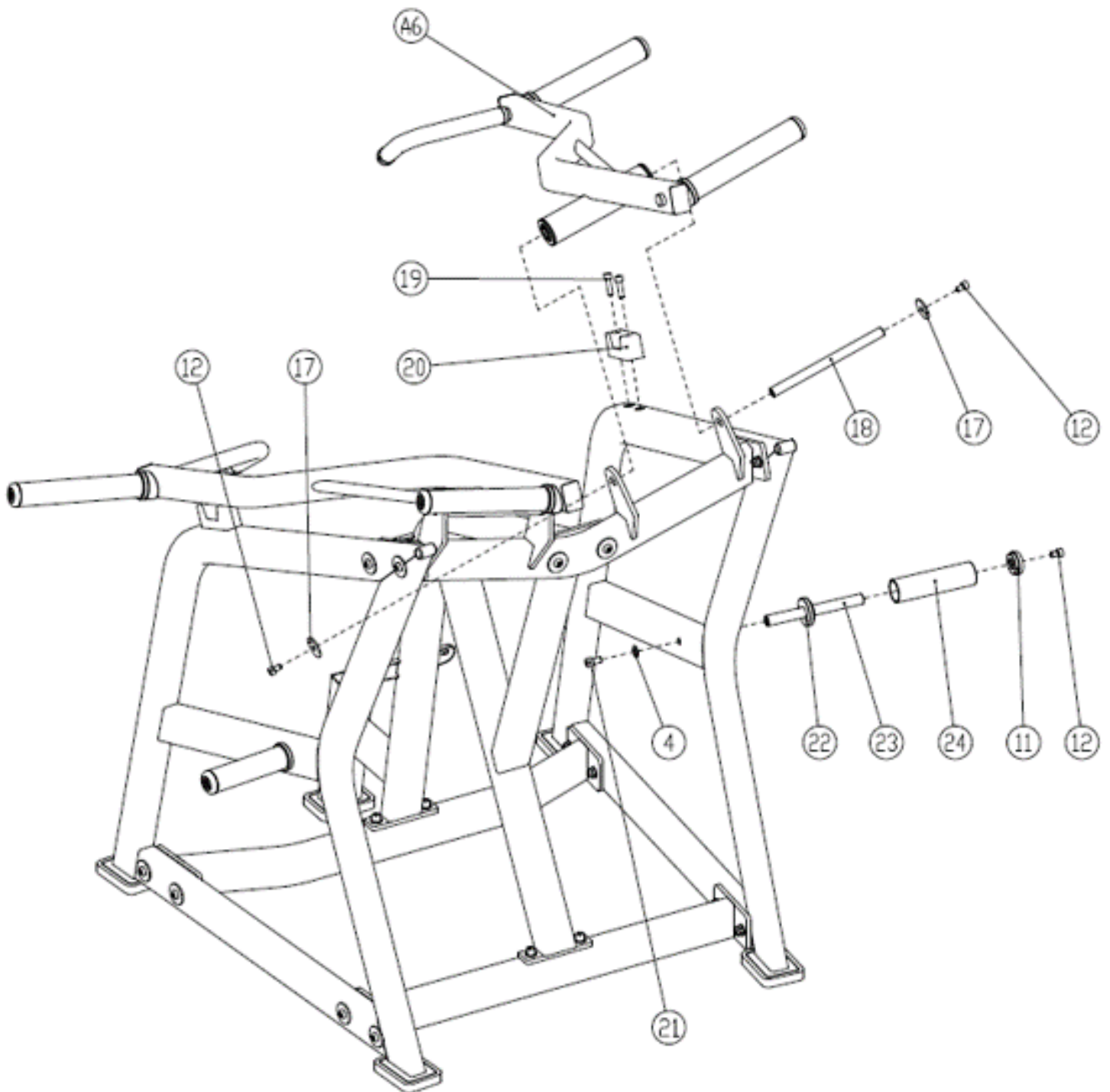

# Cushion Installation

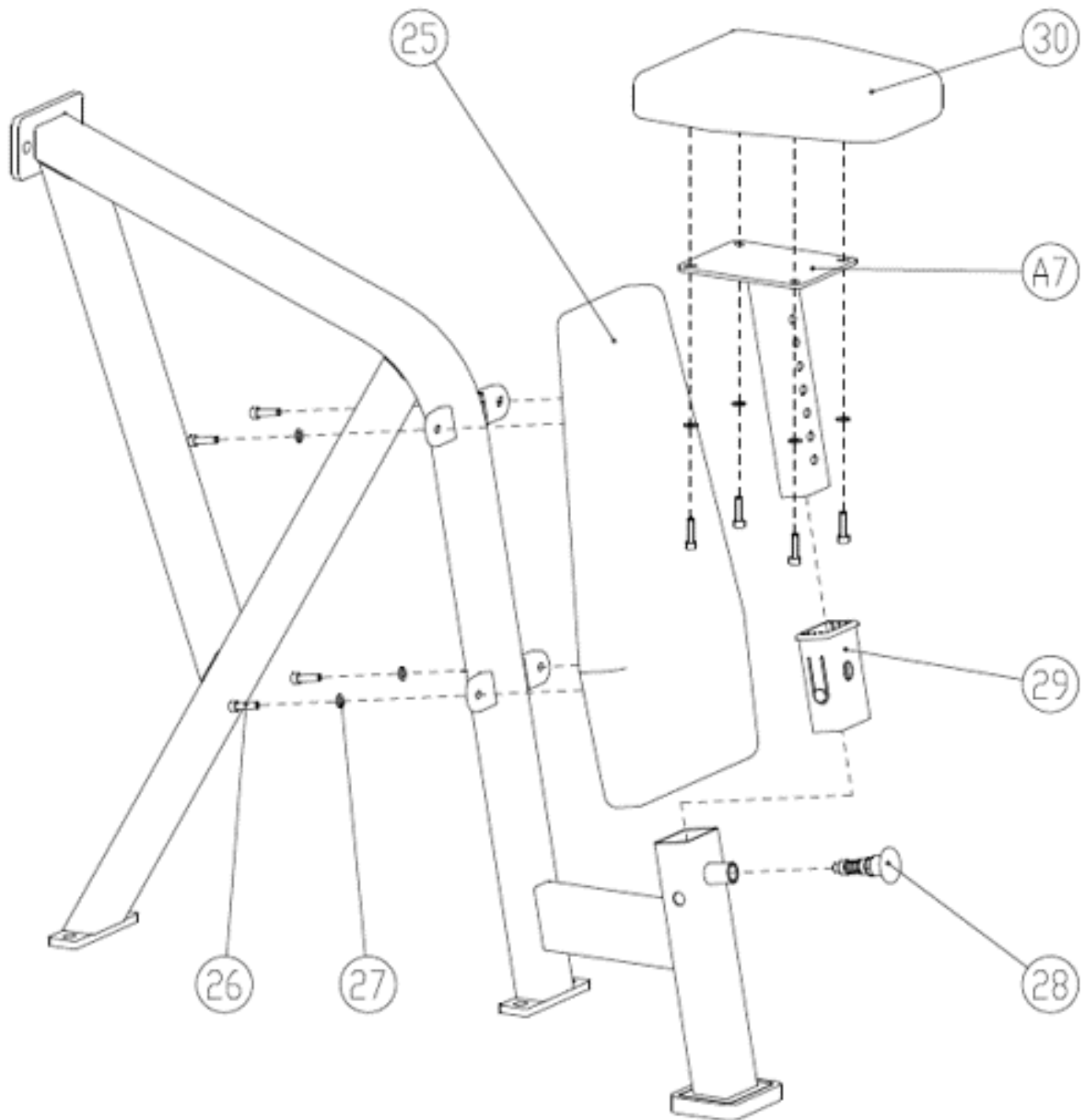



## Final Product

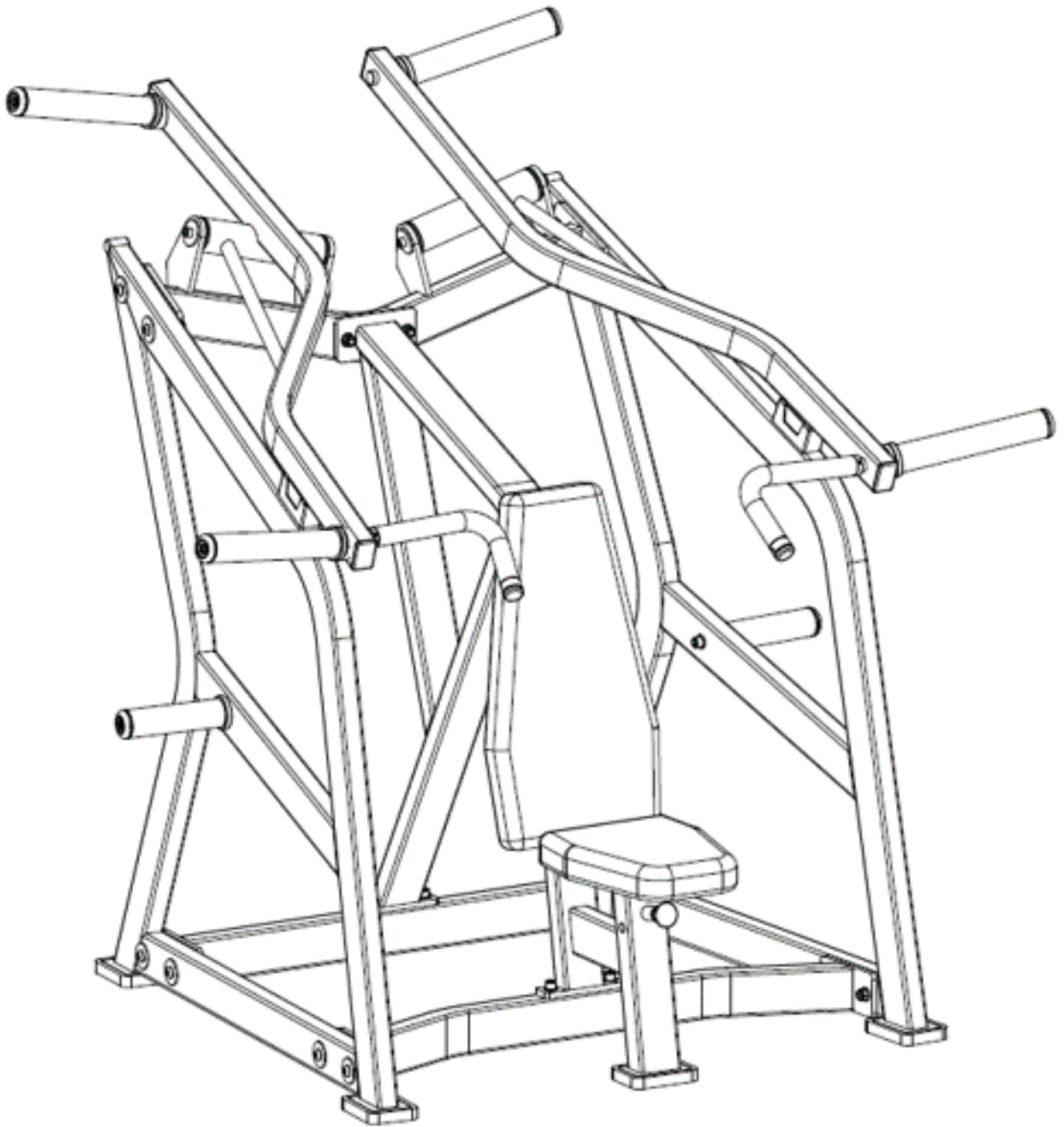

**Have a question about assembly?**



**Please contact a Gym Bro Fitness Team Member!**

**Hours of Operation:**

**Monday-Friday 9:00am - 5:00pm (PST)**

**Saturday 9:00am - 3:00pm (PST)**

**Sunday CLOSED**

**Phone: (662)GYM-BROS**

**Email: [info@gymbrofitness.com](mailto:info@gymbrofitness.com)**

**Visit Our Website: [www.gymbrofitness.com](http://www.gymbrofitness.com)**